

## 6.1 Description of Heating System

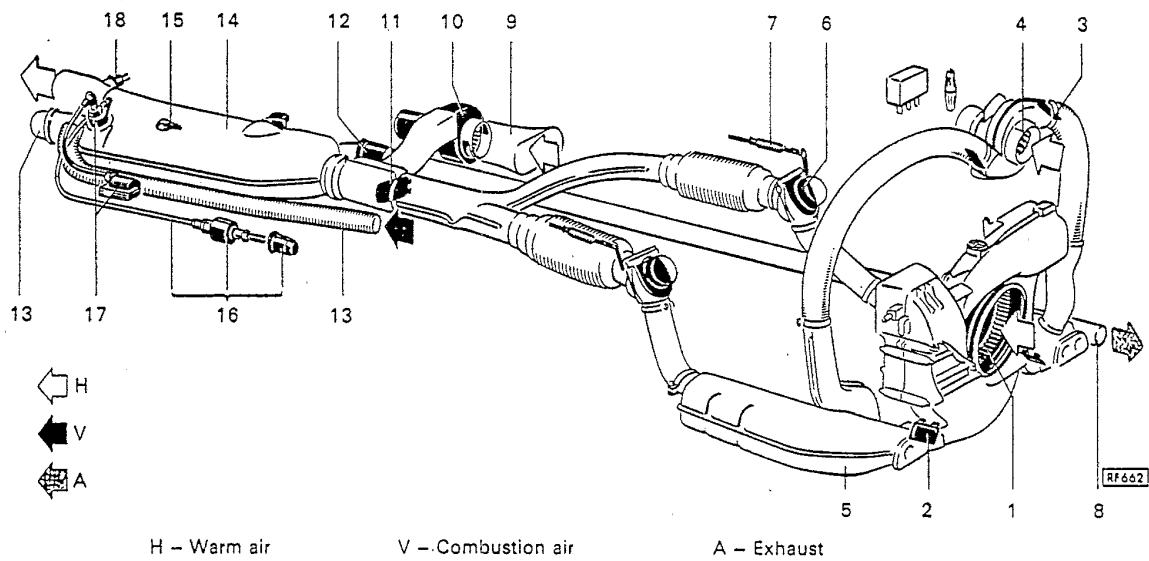

### Cooling air fan (1)

Delivers warm air to the heating system dependent on the speed of the engine.

### Warm air blower (4)

Forces warm air through heat exchanger (5) towards BA 6 heater when the speed of the cooling air fan (1) is low.

### Heat exchanger (5)

### Air control flaps (6)

### Exhaust pipe (8) and injector (12)

Conducts exhaust gas away with minimum drop in pressure.

### Circulation blower (10)

Forces air through the heater (14) vehicle engine is not running. When engine is running at high speeds, the blower also runs but does not deliver air.

### Flap housing (11)

The flap closes the air duct from the air circulation blower (10) to the heater (14) when the percentage of air from the engine heating is higher (when engine is running fast).

The flap closes the air duct from the engine heating to the heater (14) when the engine is not running.

**Combustion air system (13)**

(consists of flexible hose and blower)

The combustion air blower draws air from the hollow cross member and delivers it to the heater combustion chamber where it mixes with the fuel.

**BA 6 heater (14)**

Supplements the warm air supply to the passenger compartment according to the heat output from the engine heating system.

**Fuel system (16)**

(consists of filter and metering pump)

Supplies fuel to the heater combustion chamber in conjunction with the air being delivered by the combustion air blower.

**Ignition system (17)**

(consists of glow-spark plug and coil)

**Regulation system (18)**

(consists of temperature sensor (18) and temperature regulating switch).

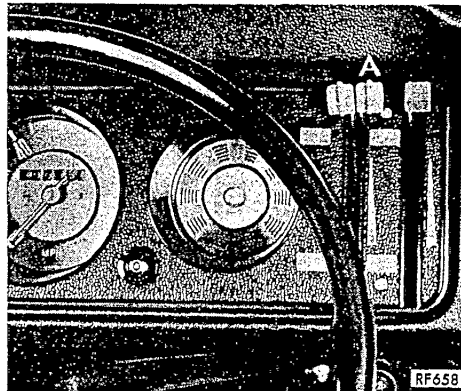

**Operation**

**Switching BA 6 heater on**

- a – Press engine heating lever (A) down fully.  
(This operates the main switch to complete regulation circuit and opens the air flaps.)
- b – Press temperature regulating switch in and turn it 90° clockwise.  
(Mechanism in switch limits heater running time to about 10 minutes.)
- c – Turn switch to the right to set amount of heat required.

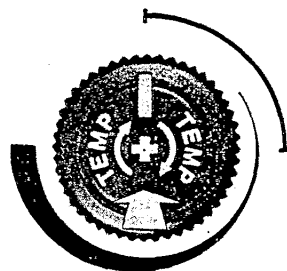

RF659

## 6.1 Description of Heating System

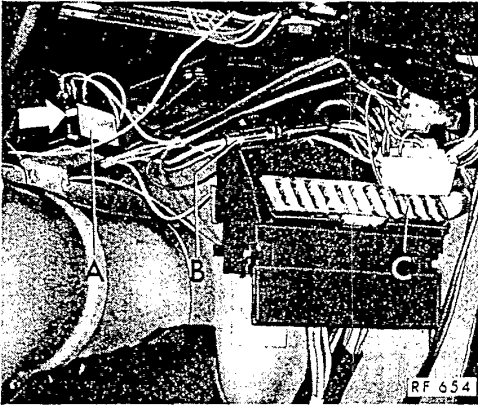

### Safety devices

#### 1 – Safety switch (A)

The switch operates when the heater fails to ignite properly or there is no fuel (Press switch lever in direction shown by arrow).

#### 2 – Main fuse (B) – 16 Amp. –

(Separate fuse with red wires) is for:

- Combustion air blower
- Air circulation blower
- Metering pump
- Ignition
- Control current circuit when engine is not running

#### 3 – Fuse (C) – 16 Amp. –

This is the 10th fuse in the fuse box. It is for the control current circuit when heater is on and vehicle is moving.

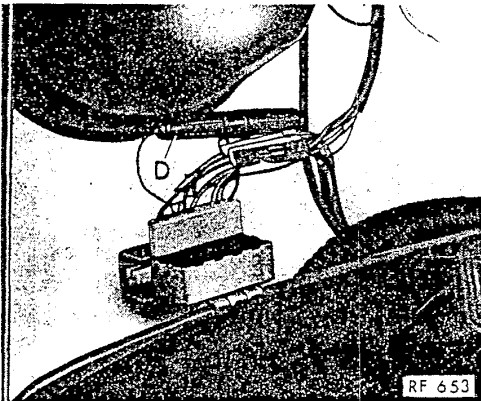

#### 4 – Overheating fuse (D) – 8 Amp. –

(Separate fuse with green wires) Operates when heat exchanger overheats because:

- a – No air is flowing through the heat exchanger.
- b – The temperature regulating switch has failed.

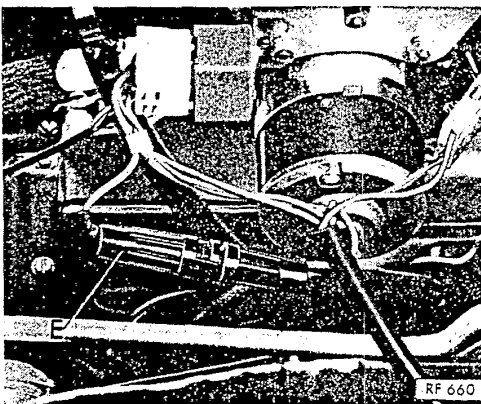

#### 5 – Fuse (E) – 16 Amp. –

This fuse is for the warm air blower. (not installed in Type 2/1600)

**Maintenance**

Every two years the following maintenance operation should be carried out on the heater:

1 – Clean filter if water can be seen in it.

2 – Check glow-spark plug:

a – Clean if very sooty

b – Check electrode gaps

c – Check internal resistance of spark  
plug part

Fit a new plug if necessary.

3 – Clean strainer in plug connection:

Loosen the carbon deposits with a tooth  
brush and then blow it off with compressed  
air (repeat).

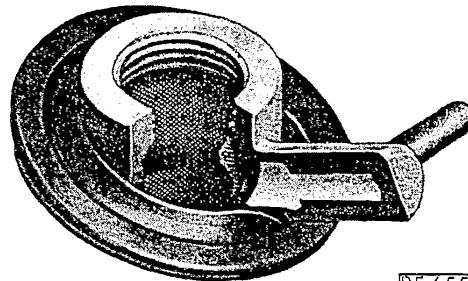

If this is not done, trouble will be experienced with heater ignition during start-up and regulation and this will in turn cause the safety switch to operate at irregular intervals.

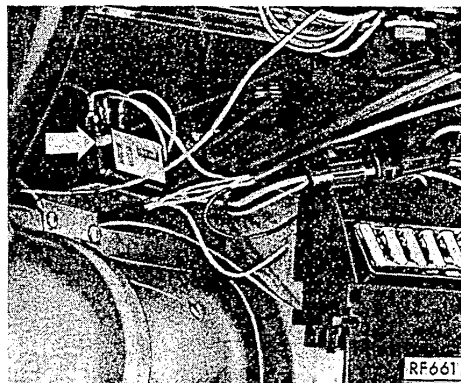

Safety switch

## Γ 6.1 Description of Heating System

### Technical data

Heat output		
of BA 6 heater at maximum temperature setting .....	approx.	5100 kcal/h to 5900 kcal/h
Heat output		
of engine heating with engine at maximum speed ...	approx.	12,500 kcal/h
Fuel .....		vehicle fuel
Fuel consumption		
at maximum temperature .....	approx.	1.1 liter/h to 1.3 liter/h
Operating range		10–14 volts
at an ambient temperature of .....		–40 °C to 20 °C
Nominal voltage .....		12 volts

Current draw in various conditions		Type 2/1600 in watts	Type 2/1800 in watts
Current draw when vehicle is in motion			
during start-up with engine running fast .....	approx.	240	300
during start-up with engine running slowly .....	approx.	255	400
when heating with engine running fast .....	approx.	100	160
when heating with engine running slowly .....	approx.	215	260
Current draw when engine is not running,			
during start-up .....	approx.	240	240
When heating .....	approx.	100	100

CO content in exhaust gas over entire operating range (except start-up) .....	less than 0.2 % of volume
Start-up time (glow time of glow-spark plug) .....	less than 70 seconds
Run-on time .....	approx. 80 to 160 seconds

### Technical data

Description of Heating System

**F 6.1**

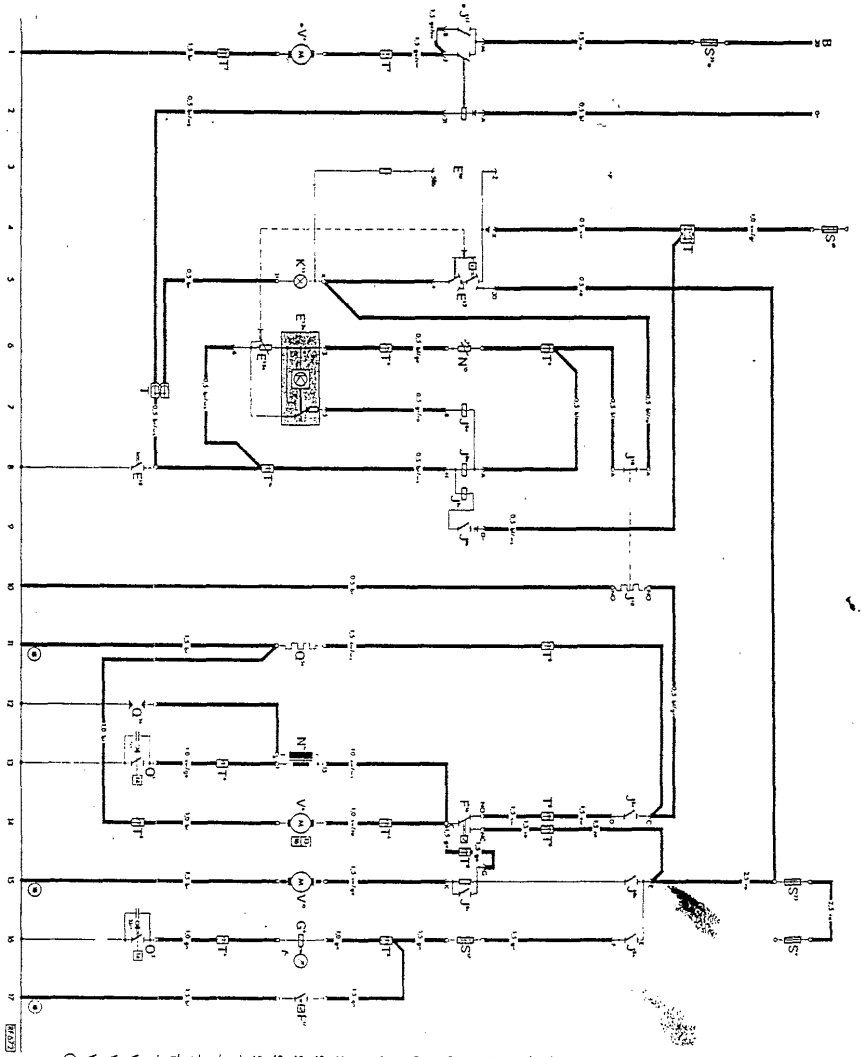

Designation	In current track
B <sup>+</sup> - to starter terminal 30	1
D+ - to voltage regulator	2
E1a - terminal 58 b vacuum	3
E2a - Temperature regulating switch (switch part)	5
F12a - Temperature regulating switch (regulating part)	6
E12b - Temperature regulating switch (electronic)	6, 7
E1a - Main switch	8
F1e - Thermostats	14
F17 - Overheating switch	17
G4 - Metering pump	16
J8a - Relay	7, 14, 16
J8b - Relay	8, 9, 15
J8c - Relay	8, 15
J10 - Safety switch	8, 10
J11a - Relay - Warm air blower	1, 2
K11 - Warning lamp	5
N10 - Temperature sensor	6
N11 - Coil	13
O1 - Contact for coil in combustion air blower (one impulse per revolution)	13
O2 - Contact for metering pump in combustion air blower (one impulse every 33 revolutions)	16
O4 - Glow-spark plug - Glow element	11
O5b - Glow-spark plug - Electrodes	12
Sa - Ninth fuse in fuse box	16
S10 - Tenth fuse in fuse box	4
S17 - Overheating fuse - 8 Amp. (separate)	16
S23 - Main fuse - 16 Amp. (separate)	15
S25 - Fuse - 16 Amp. - for warm air blower	1
T - Cable adaptor (on instrument panel)	4
T1b - Cable connector, single (on instrument panel)	8
T2 - Cable connector, double on warm air blower	1
T4 - Cable connector on combustion air blower	13, 14, 16
T8 - Cable connector 8 pin (on water container bracket)	5, 6, 11, 14, 16
V** - Warm air blower	1
V6 - Combustion air blower	14
V10 - Air circulation blower	15
Ⓢ - Heater:sealing screw on coil bracket	

ro = red  
 sw = black  
 go = yellow  
 bl = blue  
 br = brown  
 ws = white  
 gn = green  
 gr = gray

\* not installed on Type 21600

On vehicles with Canadian equipment the lamp (K 11) in the knob of the temperature regulating switch (E 13) is wired as an illuminating lamp.  
 Terminal 58b of temperature regulating switch E 13 is connected to terminal 58b on lighting switch.  
 Terminal K of temperature regulating switch remains vacant.  
 Terminal 4 of temperature regulating switch is connected to terminal A of safety switch.  
 Terminal 31 of temperature regulating switch is connected directly to earth.

**Explanation**

**To switch heater on:**

Testing should always be carried out with the engine running at a fast idle.

a – Start vehicle engine

Voltage can be measured at:

Terminal D+ on regulator

Relay for warm air blower (J 11) operates.  
The warm air blower (V 4) starts to deliver.

b – Press main switch lever (E 16) down fully. Heater flaps are opened. Engine heating starts to work.

c – Switch on temperature regulating switch (E 13) and set heat. The warning lamp (K 11) lights up and heater booster starts to heat.

**Start-up:**

The heater ignites within 70 seconds if the air drawn in is at room temperature. The start-up process is terminated by the thermo-switch (F 16).

Voltage can be measured at:

Terminals 30-4 of temperature regulation switch (E 13)  
Terminals A-A of safety switch (J 10)

Relay (J 8) operates contacts E-G and E-K.

Terminals of fuse (S 23) 16 amp.  
Terminals E-K of relay (J 8b)

The air circulating blower (V 10) starts to work.  
The series resistance for the air circulating blower (V 10) in relay reduces the output when there is no voltage at terminal D+ on relay. This is the case when the engine is running (voltage at terminal X on temperature regulating switch). The resistance in relay is bridged by relay contact (J 8c) when there is no voltage at terminal D+ on relay.

Terminal C of thermo-switch (F 16)

The combustion air blower (V 6) starts to work.

Terminal 15 of ignition coil (N 11)

At every revolution of the combustion air blower (V 6) the ignition coil (N 11) receives an impulse via the breaker contacts (O 1).

No voltage or a low voltage can be measured at:

Main switch (E 16)  
Terminals 6-5 of temperature regulating switch (E 13b)

– about 3 volts –  
Terminal B of relay (J 8a)  
– about 3 volts –

Relay (J 8a) operates the contacts E-F and C-D.

---

Voltage can be measured at:

Terminal NO of thermo-switch (F 16)

The glow element of the glow-spark plug (Q 5 a) is energized. It warms the fuel-air mixture to make it readily combustible. It is then ignited by the sparks from the glow-spark plug (Q 5 b).

Overheating fuse (S 17) 8 amps

The fuel pump (G 6) starts to deliver fuel. At every 33rd revolution of the combustion air blower (V 6) the fuel pump (G 6) receives an impulse via the contact breaker (O 2).

### Heating

When the heater has ignited and warmed up, the thermo-switch (F 16) operates the contacts C–NC. This ends the start-up process.

The following are de-energized:

Terminal NO of thermo-switch (F 16)

The glow element of the glow-spark plug (Q 5 a) is de-energized.  
The safety switch (J 10) is out of action.

### Regulation

During regulation there are two voltages at terminal 5 of the temperature regulating switch (E 13 b). These voltages are controlled by the temperature selection via the electronic circuitry (E 13 b) and the temperature sensor (N 10). When the heater reaches the high heat output, the temperature sensor (N 10) records a high temperature and the temperature regulating switch (E 13 b) indicates a high voltage at terminal 5 as the switching value for the relay (J 8 a).

Voltage can be measured at:

Contact 5 of temperature regulating switch (E 13 b)  
Contact B of relay (J 8 a)

The relay separates the contacts E–F and D–C.

The following are de-energized:

Contact F of relay (J 8 a)  
Contacts of fuse (S 17)

The fuel pump stops delivering fuel and the heat exchanger cools down. The temperature of the warm air also drops. The heat exchanger however, cools down so far during the regulating process that the thermo-switch can operate contacts C–NO for less than two minutes because the temperature sensor (N 10) registers the low temperature necessary for the switch-on process beforehand. Contact 5 on the temperature regulating switch (E 13 b) receives a low voltage as switching current for the relay (J 8 a). Due to the internal resistance of the electronic circuitry (E 13 b) terminal 5 cannot reach the ground potential.

No voltage or a low voltage can be measured at:

Contact 5 of temperature regulating switch (E 13 b)  
– about 3 volts –  
Contact B of relay (J 8 a)  
– about 3 volts –

---

## DESCRIPTION OF HEATING SYSTEM

Relay (J 8a) connects the contacts E-F and D-C.

Voltage can be measured at:

Terminal F of relay (J 8a)

The fuel pump (G 6) starts delivering fuel.

### Operation of overheating circuit

If the heater should overheat, the overheating switch (F 17) closes and causes a short circuit which blows the 8 amp fuse (S 17). The overheating switch (F 17) responds if insufficient warm air is flowing past the heat exchanger or the temperature regulating switch (E 13b) does not regulate.

This de-energizes:

Terminal of fuel pump (G 6)

The flame goes out and the run-on starts.

### Operation of safety switch

The safety switch (J 10) responds when the thermo-switch (F 16) holds the contacts C-NO for longer than roughly two to four minutes because combustion has not taken place in the heater, re-ignition has not taken place after regulation, or because the thermo-switch (F 16) is defective.

Voltage can be measured at:

Terminals C-NO of thermo-switch (F 16)

Terminal D-C of relay (J 8a)

The glow element of safety switch (J 10) heats up for about two to four minutes and then the contact connection A-A is interrupted.

The following are de-energized:

Terminal A of relay (J 8)

All connections in relay (J 8) are interrupted.

Terminal G of relay (J 8)

Terminal K of relay (J 8)

The combustion air blower (V 6) stops.

The ignition coil (N 11) is de-energized.

The air circulation blower (V 10) stops.

Terminal F of relay (J 8)

The fuel pump (G 6) stops working.

### Switching heater off:

Turn knob of temperature regulating switch (E 13) back to the click stop position. The warning lamp (K 11) goes out. Press main switch (E 16) down to open earth contact.

The following is de-energized:

Terminal (M) on temperature regulating switch (E 13b)

Terminal A on relay (J 8)

All connections in relay (J 8) are interrupted.

### Run-on:

The run-on lasts for about 80-160 seconds at an ambient temperature of 20 °C and is shorter at lower temperatures. The run-on is necessary in order to clear all traces of gas from the heat exchanger and cool it down. The thermo-switch limits the run-on period.

The following is de-energized:

Terminal F of relay (J 8a)

The fuel pump (G 6) stops working.

Voltage can be measured at:

Terminals of fuse (S 23), 16 amps

Terminals NC-C of thermo-switch (F 16)

The combustion air blower (V 6) delivers air.

Terminal G of relay (J 8)

Terminal K of relay (J 8)

The air circulation blower (V 10) delivers air.

When the heat exchanger has cooled down, the thermo-switch (F 16) operates contacts C-NO.

The following is de-energized:

Terminal C of thermo-switch (F 16)

Terminal K of relay (J 8)

Air circulation blower (V 10) and combustion air blower (V 6) are de-energized and the run-on is finished.

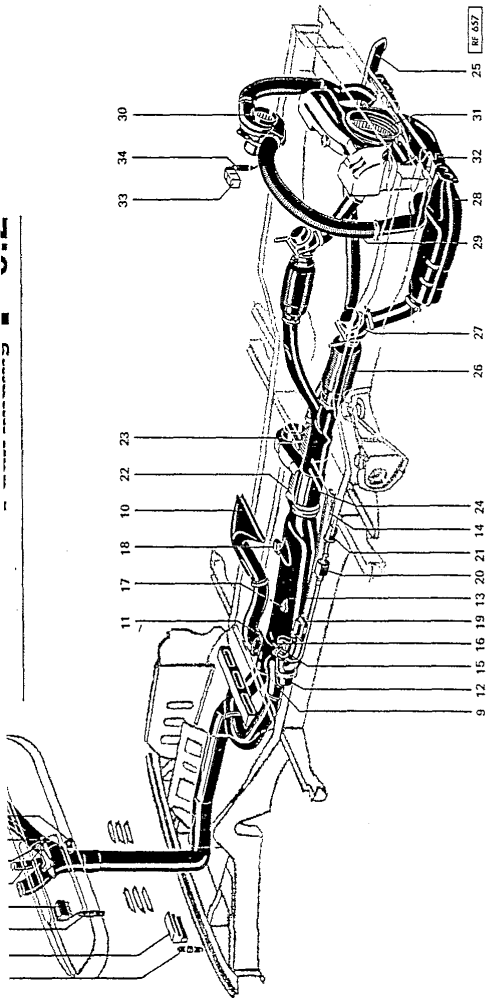

W 657

Fault finding chart

Fault	Conditions	1	2	3	4	5	6	7	8	9	10	11	12	13	14	15	16	17	18	19	20	21	22	23	24
10th fuse in fuse box blown	Engine running Main switch on (lever 3) Temperature regulating switch (1) on																								
Separate 16 Amp. fuse for warm air blower (34) blown	Main switch on (lever 3) Engine running																								
Main fuse (6) blown	Main switch on (lever 3) TRIS (1) on																								
Switch safety (5) has operated	Main switch on (lever 3) TRIS (1) on																								
Overheating switch (17) and 8 Amp. fuse have operated	Main switch on (lever 3) TRIS (1) on																								
Heater does not run-on	Heater and engine switched off																								
Air circulation blower (23) does not run at two speeds	Main switch on (lever 3) TRIS (1) on Ignition switched on and off																								
Heat output inadequate and/or heater uses too much fuel	Engine running Heater switched on																								
Air circulation (23) and combustion air blower (12) continue to run after run-on period although the heater is switched off	Engine running Main switch on (lever 3) TRIS (1) has just been switched off																								
Warm air blower (30) continues to run	Heater and engine have just been switched off																								
Heater smokes	Main switch on (lever 3) TRIS (1) on																								

---

#### **g air fan (1)**

e fault: Air flaps (2) not closing properly so that the blower (4) forces warm air out to atmosphere when engine is running slowly.

f fault: At low engine speeds, insufficient warm air passes through the heat exchanger (5) to the heater (14) and the heat radiating ability of the heat exchanger is not fully utilized. The heat then deficient in the passenger compartment is made up by the heater. This in turn causes the heater to use an excessive amount of fuel.

r: Replace the flaps (2).

#### **air blower (4)**

e fault: Plastic flaps (3) broken.

f fault: At high engine speeds warm air flows from the cooling fan through the warm air blower to atmosphere. Insufficient air passes through the heat exchanger (5) and the heat then deficient in the passenger compartment has to be supplied by the heater. This causes the heater to use too much fuel.

r: Replace housing with flaps.

#### **xchanger (5)**

e fault: Corrosion damage.

f fault: Loss of warm air, excessive high fuel consumption in heater.

r: Replace heat exchanger (5).

#### **I flaps (6)**

e fault: Flaps (6) not opening and closing simultaneously. Bowden cables (7) not properly adjusted.

f fault: Heat produced by engine is not fully utilized and heater has to supply heat unnecessarily (excessive fuel consumption). Or heater cannot be switched on at all because main switch circuit is not being closed.

r: Adjust.

---

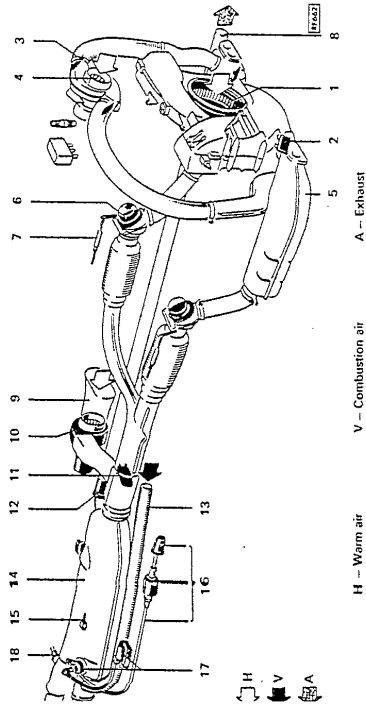

**Exhaust pipe (8) and injector (12)**

Possible fault: Blocked.

Effect of fault: 1 - Poor ignition.  
 2 - No ignition.  
 3 - Damage to combustion air blower.  
 Safety switch operates.

Remedy: Clean or replace.

**Air circulation blower (10)**

Possible fault: Electrical defect in motor (10).

Effect of fault: Overheating switch (15) operates when engine is not running, blows fuse.

Remedy: Check blower motor (F 6.3 / 2-1).

**Heater housing (11)**

Possible fault: Damaged by corrosion.

Effect of fault: Overheating switch (15) operates and fuse blows.

Remedy: Replace.

**Combustion air supply (13)**

Possible fault: Flexible hose fallen off at rear cross member.

Effect of fault: The difference in pressure caused by wind when vehicle is moving or side wind on the intake connection of blower alters the flame formation in heater. May even destroy the combustion air blower. The safety switch operates.

Remedy: a - Re-route hose (F 6.4 / 1-2).  
 b - Check combustion air blower F 6.3 / 1-2.

**Heater (14):**

Possible fault: see pages F 6.3 / 1-2.

Effect of fault: Safety switch operates.

Remedy: see page 6.3 / 1-2.

**Fuel system (16)**

Possible fault: see pages F 6.3 / 1-5.

Effect of fault: 1 - Safety switch operates.  
 2 - Heater smokes.

Remedy: see page F 6.3 / 1-5.

**Ignition system (17)**

(consists of glow-spark plug and coil)

Possible fault: see pages F 6.1 / 3-1 and F 6.3 / 2-2.

Effect of fault: Safety switch operates (see page F 6.2 / 1-1).

Remedy: see page F 6.1 / 3-1 and F 6.3 / 2-2.

**Regulation (18)**

(consists of temperature sensor (18) and temperature regulating switch)

Possible fault: see page F 6.3 / 1-3 and F 6.3 / 1-4.

Effect of fault: 1 - The overheating switch operates (see page F 6.2 / 1-1).  
 2 - The safety switch operates (see page F 6.2 / 1-1).

Remedy: see page F 6.3 / 1-3 and F 6.3 / 1-4.

# Checking and Adjusting Parts **F 6.3**

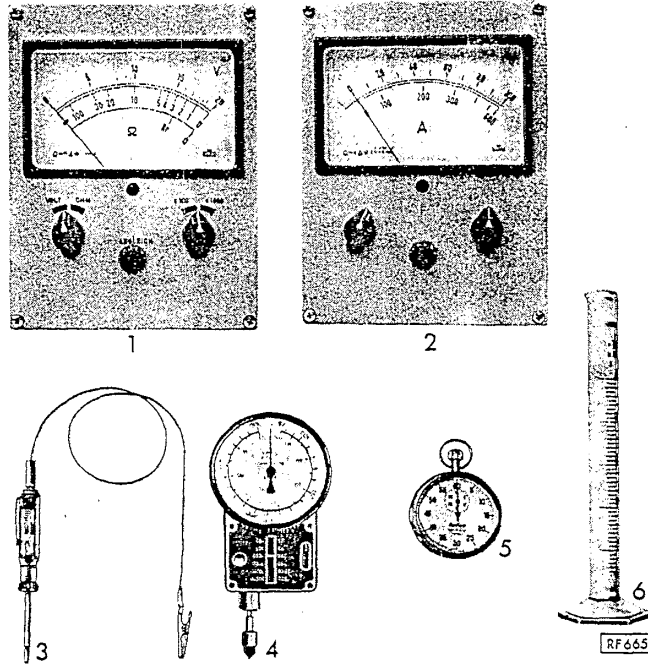

No.	Designation	Special Tool	Remarks
1	Ohmmeter/voltmeter		Range 0-20 V
2	Ammeter		Range 0-50 A
3	Test lamp		12 V
4	Rev. counter		0-8000 rpm
5	Stop watch		
6	Measuring glass		Capacity 25 cm <sup>3</sup>
	Special spanner	674/2	Local manufacture

## 6.3 Checking and Adjusting Parts

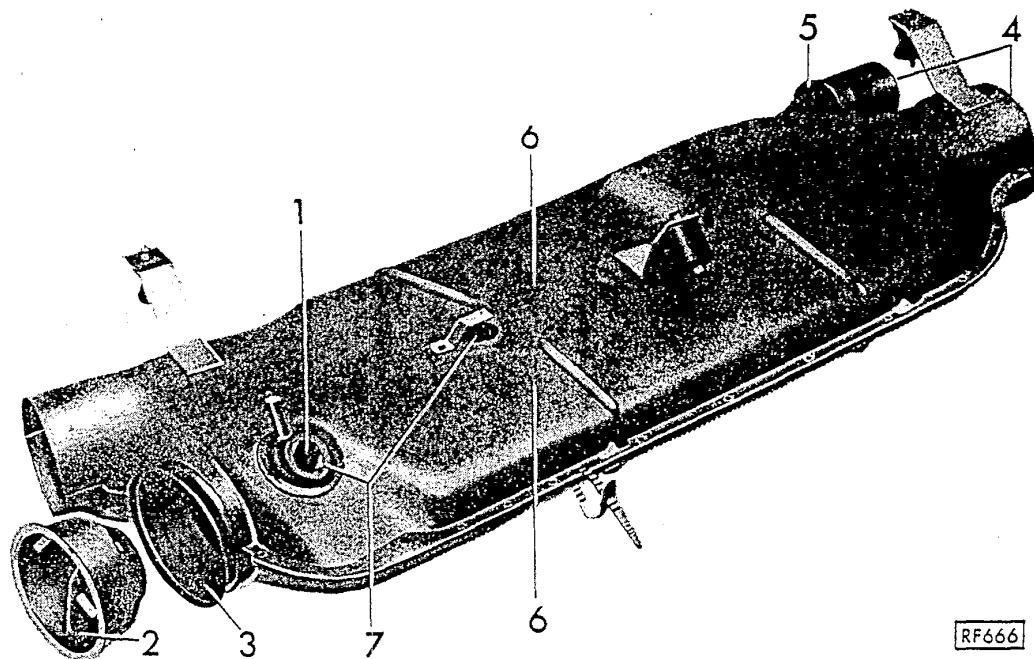

### BA 6 Heater

#### Visual check:

- 1 Clean plug adaptor with toothbrush.
- 2 Replace deflector vane housing if burned.
- 3 Clean combustion chamber.
- 4 If tar-like deposits have formed in exhaust pipe, replace. Do not attempt to burn heater out.
- 5 Clean injector.
- 6 If heater casing is distorted due to overheating – replace it.
- 7 If gaskets are damaged due to overheating or are not correctly located – replace them.

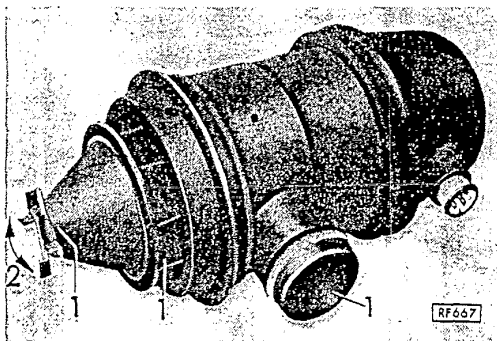

### Combustion air blower

#### Visual check:

- 1 If blower is damaged due to heat – replace it.
- 2 Turn blades to check if bearings are in order. If not, replace blower as necessary.

**Counting revolutions:**

At every 33rd revolution of the blower motor the breaker contacts for the metering pump generate an impulse and the pump makes an audible stroke.

**Pump strokes in 1 minute x 33 = motor rpm**

The speed should be 6400–7000 rpm at 12 volts after running for 10 minutes.  
Replace if necessary.

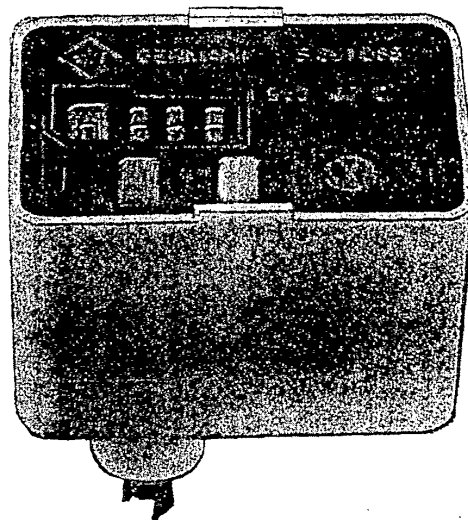

Temperature regulating switch

**Regulating ranges:**

Upper switching point . . . . . 115 to 143 °C

Lower switching point . . . . . 30 to 40 °C

The switching points can only be measured roughly with an electronic instrument near the temperature sensor.

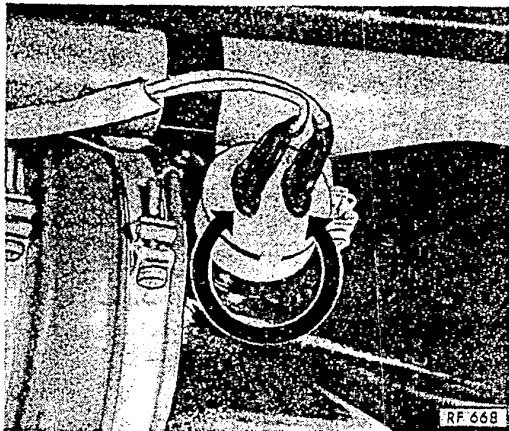

**Checking regulation:**  
(with heater installed)

Switch heater on

Check	Operation on temperature sensor	Condition simulated	Watch pump
Regulation cut-in	Disconnect wires briefly, otherwise overheating switch will work	cold air	must deliver
Regulation cut-out	Bridge contacts	hot air	must stop delivering

Replace if regulation does not take place.

Check the temperature sensor if regulation takes place.

If the heater does not regulate properly it will overheat (this can happen, for example, if the temperature sensor is disconnected). The overheating protection device will then respond in an matter of minutes.

**Temperature sensor**

The temperature sensor supplies a temperature-sensitive voltage to the temperature regulating switch.

**Properties:**

The temperature sensor is a temperature-sensitive resistance which has a high resistance value at low temperatures and a low resistance value at high temperatures.

**Resistance:**

Measured in water at 60 °C 3.5–5 kΩ

**Remedy:**

Replace if necessary

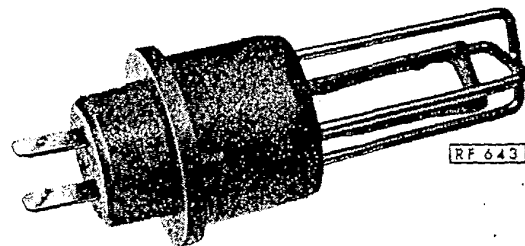

### Overheating switch

This switch operates and causes a fuse to blow and stop the current flow to the fuel pump when a defect occurs which would make the heater overheat.

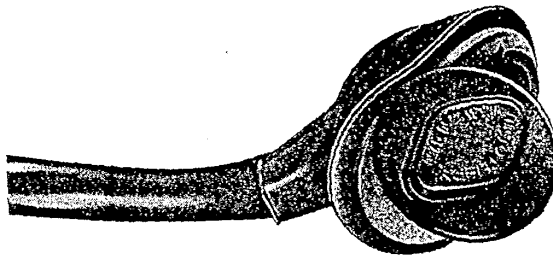

RF 645

#### Testing:

(installed)

- 1 – Switch heater on (vehicle engine not running).
- 2 – Wait for start-up time (less than 70 seconds).
- 3 – Disconnect wires on air circulation blower.
- 4 – Measure the time which elapses from the moment the blower is disconnected to the moment the pump ceases to tick (overheating fuse blown).

Specified time: 60 to 140 seconds.

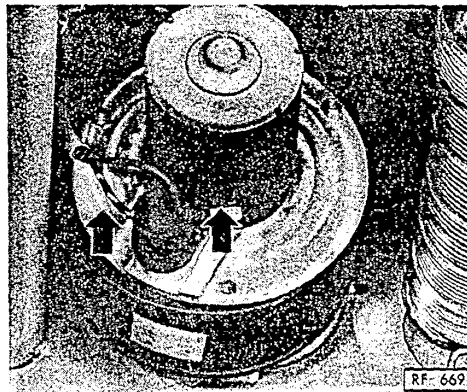

#### Remedy:

Replace if necessary.

### Fuel pump

#### Checking:

- 1 – Pull hose off pressure connection.
- 2 – Fit a piece of hose about 300 mm long on the connection so that fuel can be caught in a measuring glass.
- 3 – Switch heater on.
- 4 – Count 200 pump strokes and catch fuel delivered in the glass.

Specified amount: 18.4 to 21.7 cm<sup>3</sup> per 200 strokes.

#### Remedy:

Replace if necessary

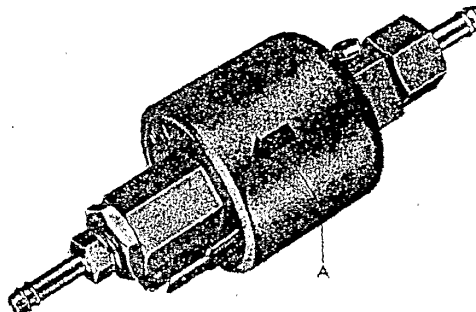

A - Flow direction

## Checking and Adjusting Parts

---

10 strokes in time with the ticking of the pump is not easy. We recommend therefore numbers 1 to 20 are written on a piece of paper and one number struck off after each

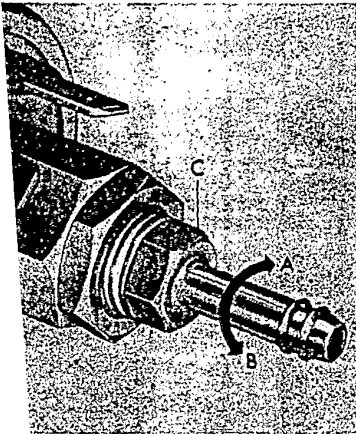

### Adjusting:

To increase consumption

= Turn valve guide C to left (arrow B)

To reduce consumption

= Turn valve guide C to right (arrow A)

Tighten the lock nut again afterwards and lock it with paint.

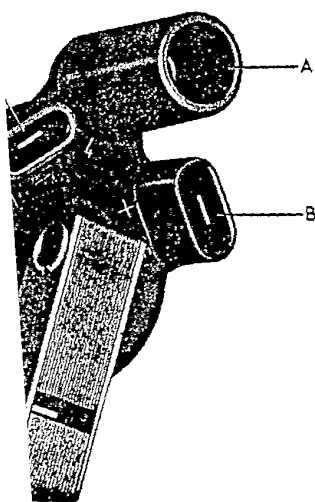

### Ignition coil

#### Current draw:

less than 1 A at 6000 sparks per minute.

Replace if necessary.

ion

**Air circulation blower**

Current draw (with engine not running)

1st stage (with 1Ω series resistance)  
3.2–3.7 A at 13 V

2nd stage  
6.8–7.2 A at 13 V

Replace motor if necessary.

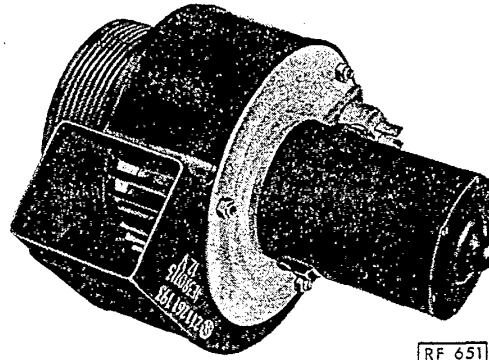

RF 651

**Hot air blower**

Current draw 6 to 7 A at 13 volts  
(installed and engine running slowly)

Replace motor if necessary.

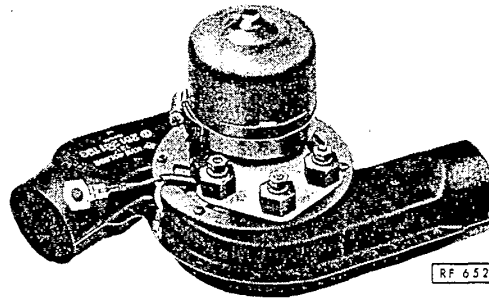

RF 652

**Thermo-switch**

- 1 – This switch controls the start-up time and the glow time of the glow-spark plug.
- 2 – It also controls the run-on time.

**Start-up time:**

Less than 70 seconds at room temperature.

**Run-on time:**

80 – 160 seconds at room temperature.

Replace if necessary.

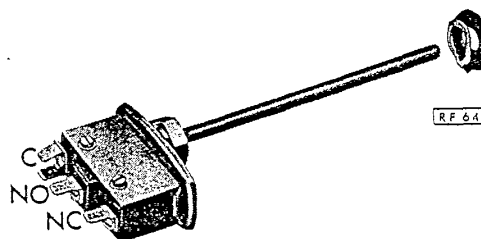

RF 647

Terminal designations:

- C – Common
- NO – Normally open
- NC – Normally closed

## F 6.3 Checking and Adjusting Parts

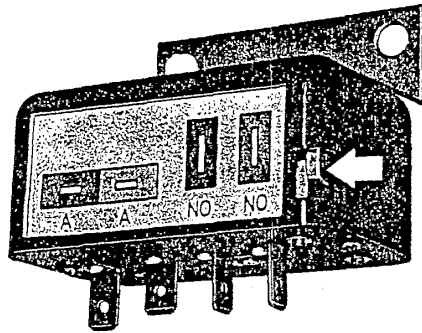

### Safety switch

This switch stops the current flow to the heater if, for some reason or other (fuel supply cut off, glow-spark plug defective) combustion does not take place within 230 seconds of switching on.

Checking:

- 1 – Remove switch.
- 2 – Connect ohmmeter to terminals A.
- 3 – Apply 12 volts to terminals NO.
- 4 – Measure time from moment voltage is applied to moment when contact is broken at terminals A.

Switch response time:

150–230 seconds at room temperature and 12 V.

Replace if necessary.

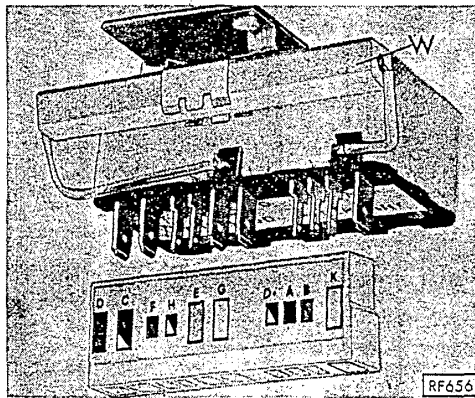

W – Resistance

### Relay

#### Resistance

Series resistance (1 Ohm) for air circulation blower.

Replace if necessary.

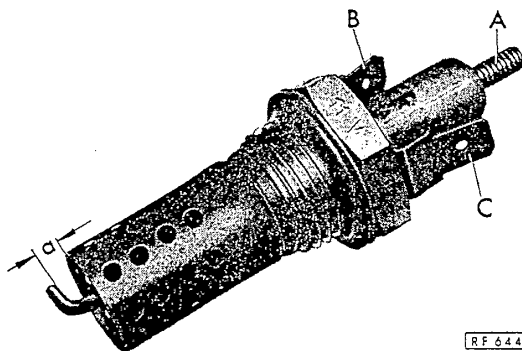

### Glow-spark plug

- |                                 |                   |
|---------------------------------|-------------------|
| Electrode gap:                  | 2.5 mm (a)        |
| Suppression resistance:         | 4 k–6 k           |
| Voltage:                        | 14 Volts          |
| Current draw of glow element at | 12 Volts = 10.2 A |
- Replace if necessary.

- A – High tension connection  
 B – Glow element connection  
 C – Earth connection

## Removing and Installing Parts **F 6.4**

### Fitting instructions

#### Combustion air blower

There is a hole in the housing of the combustion air blower (see arrow). When installing blower, ensure that this hole is at the bottom (drain for condensed water).

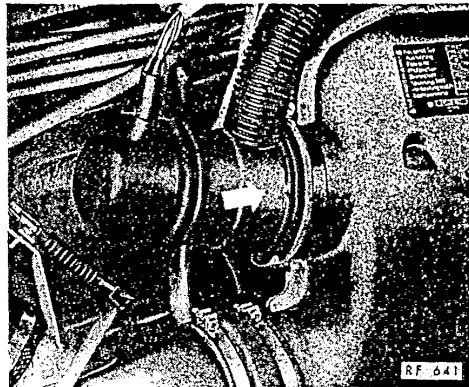

The intake hose for the combustion air must fit tightly on the blower and also in the rear support (If the hose falls off the flame in the heater will destroy the combustion air blower).

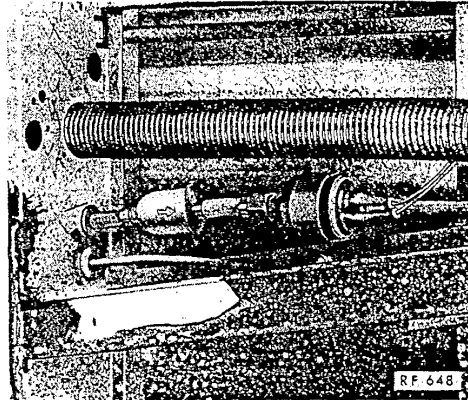

#### Air circulation blower

There is a hole in the housing of the air circulation blower (see arrow). When installing blower, ensure that this hole is at the bottom (drain for condensed water).

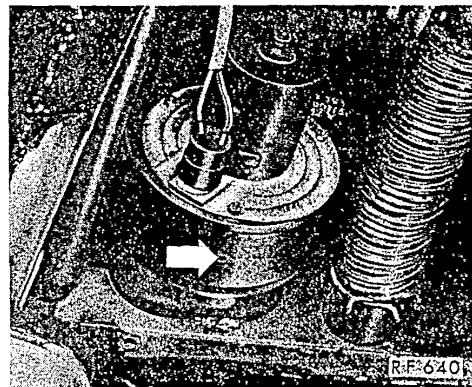

## F 6.4 Removing and Installing Parts

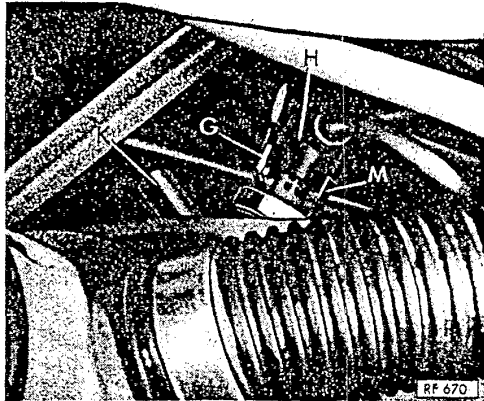

K - Fuel connection  
G - Glow element connection, plus  
M - Earth connection

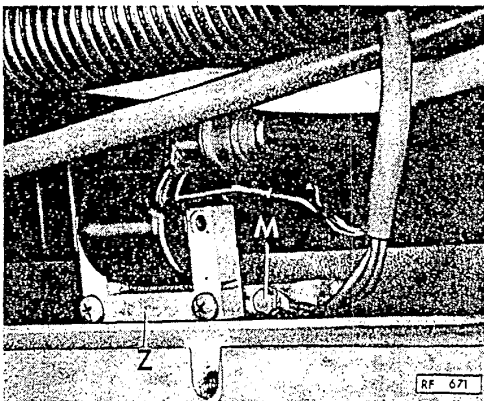

Z - Coil  
M - Earthing point on coil bracket

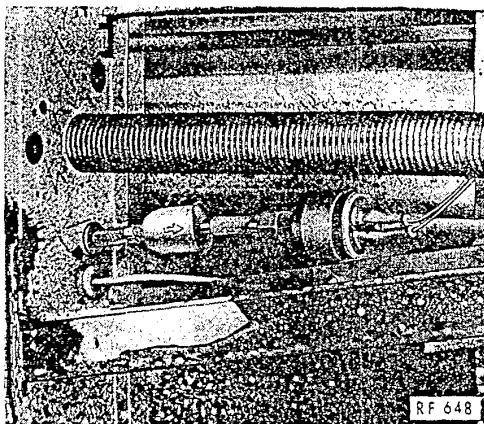

### Glow-spark plug

The illustration shows what can be done wrong:

- a - The terminals of the plug are touching the high tension connector (H). They must be pressed away so that sparks from the central electrode cannot arc through the rubber to the low tension wires.

If the plug is installed as shown, the heater will have ignition trouble (safety switch will respond).

- b - Earth wire from plug to earthing screw on coil bracket is not connected.

### Fuel pump, Filter

Use clips when fitting.

**Thermo-switch**

The thermo-switch has a feeler tube which projects into the combustion chamber. This tube is sensitive to bending forces so note the following:

- 1 – Roll the rubber grommet off and on instead of pulling or pushing it so that a minimum of force is required.
- 2 – After removing union nut pull switch out vertically and very carefully.

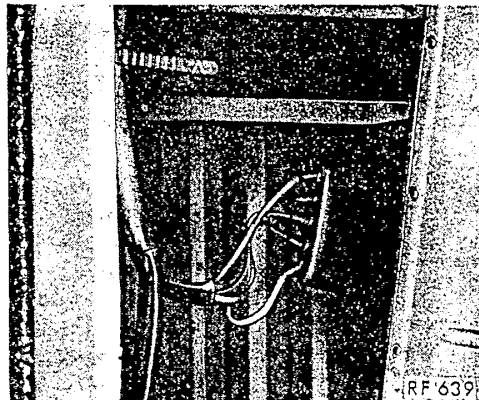

**Safety switch**

**Caution**

Disconnect battery earth when working on switch.

The temperature regulating switch will be destroyed by short circuit current if the wires touch one another or vehicle mass when disconnected.

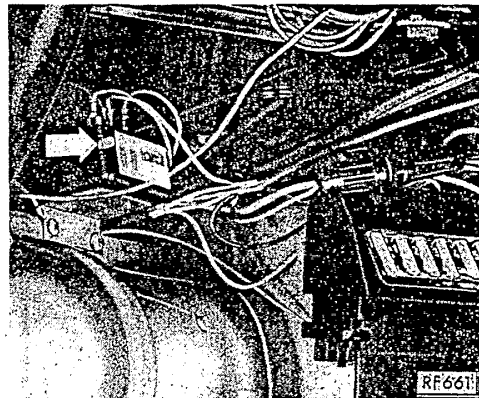

**Temperature regulating switch**

**Caution**

- 1 – Disconnect battery earth when working on switch.
- 2 – In addition to the multi-pin connector for the switch there are two tabs for terminals 31 and K. If the wires to these terminals are interchanged the switch will be damaged by the short circuit.

